



ARC 200

Item# 164609

OPERATOR'S MANUAL



Read carefully and understand RULES FOR SAFE OPERATION and instructions before operating. Failure to follow the safety rules and other basic safety precautions may result in serious personal injury.

ARC 200
Item# 164609
Operation Instructions

For technical questions and replacement parts, please call 1-800-222-5381.

Thank you very much for choosing a NORTHERN TOOL + EQUIPMENT CO., product. For future reference, please complete the owner's record below:

Model: _____ Purchase Date: _____

Save the receipt, warranty information and this owner's manual. It is important that you read the entire manual to become familiar with this product before using it.

This machine is designed for certain applications only. Northern Tool + Equipment strongly recommends that this machine not be modified and/or used for any application other than that for which it was designed. If you have questions relative to a particular application, DO NOT use the machine before you contact Northern Tool + Equipment to determine if it can be performed on the product.

Before using this welding unit, please read the following instructions carefully.

SAVE THIS MANUAL

You will need this manual for the safety warnings and precautions, assembly (if any), operating, inspection, maintenance and cleaning procedures, parts list and assembly diagram. Keep your receipt and this manual in a safe and dry place for future reference.

Please read and save these instructions. Read through this owner's manual carefully before using product. Protect yourself and others by observing all safety information, warnings, and cautions. Failure to comply with instructions could result in personal injury and/or damage to product or property. Please retain instructions for future reference.

200amp AC Stick Welder

Description

ARC200 AC Arc Welder comes complete with handle and wheels for portability. Operates on AC single phase 230v 60HZ/ 50amp circuit breaker is required. Complete with weld cables and thermal protection. For welding mild steel and alloys with electrodes up to 5/32" on materials up to 3/8". Great for farm and light industrial applications.



Specifications and Dimension

DESCRIPTION	SPECIFICATIONS
Power supply	1ph-230V-60HZ
No-load voltage	50V
Output Range	65-200A
Duty cycle	10%@180A
Suggested electrodes	E6011, E6013, E7014, E7018AC
Electrode Diameter	1/16", 5/64", 3/32", 1/8", 5/32"
Dimensions L X W X H	17.3"x14.8"x28.1"
Weight	57lbs

Removing from the carton

- 1.1 Remove cartons, bags or Styrofoam containing the welder and accessories.
- 1.2 Check the contents with the packing list below.

ITEM	QTY.
Arc Welder	1 unit
Handle	1 pc
Wheel kit (axle, wheels , axle holder etc)	1 sets
Support	1pc
Fastener pack	36pcs
Operator's Manual	1pc

- 1.3 After unpacking unit, inspect carefully for any damage that may have occurred during transit. Check for loose, missing, or damaged parts. Shipping damage claim must be filed with carrier.

Know your Welder

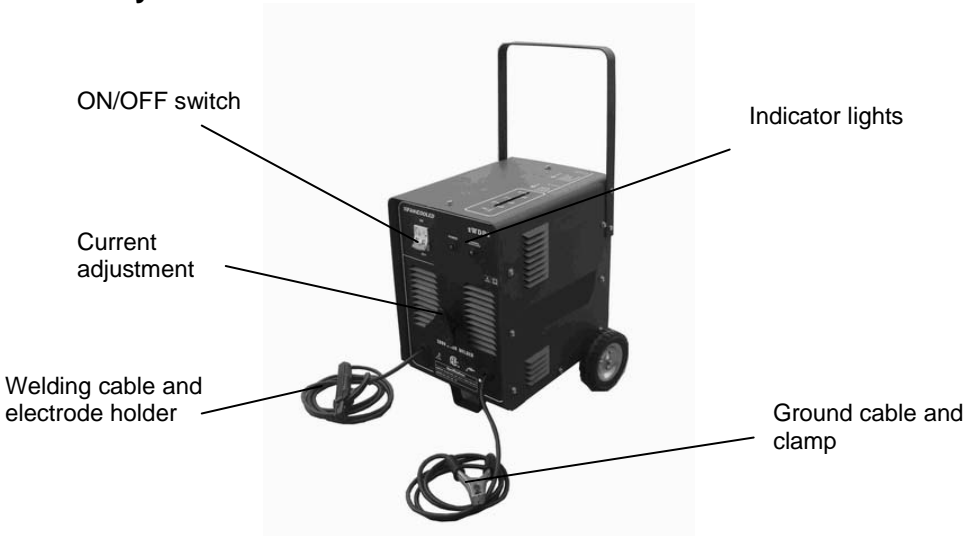

ON/OFF Switch

In the "off" position no power is being supplied to the electrode holder. In the "ON" position power is supplied to the main transformer and control circuit

Indicator Lights

There are two indicator lights: 1) Power and 2) Thermal Overload. When the machine is turned on, the power indicator will be on. When the thermal overload indicator is on, it indicates the machine has exceeded the duty cycle and the internal temperature is too high. The machine will turn off automatically but the fan will remain on to cool down the internal components. When the internal temperature has decreased, the machine will turn on automatically.

Ground Cable and Clamp

The ground cable and clamp are attached to the work piece to complete the flow of current needed to weld.

Welding Cable and Electrode Holder

One end of the cable is connected to output connector of the welder. The electrode is held in the electrode holder for welding.

Current Adjustment

Current adjustment is on the front panel of machine. It has infinite current output adjustment from 60 to 180 amps.

Power Cord

The power cord connects the welder to the 230 volt power supply. A 50 amp plug is supplied.

General Safety Information

1.1 Your Welding Environment

- Keep the environment you will be welding in free from flammable materials.
- Always keep a fire extinguisher accessible to your welding environment.
- Always have a qualified person install and operate this equipment.
- Make sure the area is clean, dry and ventilated. Do not operate the welder in humid, wet or poorly ventilated areas.
- Always have your welder maintained by a qualified technician in accordance with local, state and national codes.
- Always be aware of your work environment. Be sure to keep other people, especially children, away from you while welding.
- Keep harmful arc rays shielded from the view of others.
- Mount the welder on a secure bench or cart that will keep the welder secure and prevent it from tipping over or falling.

1.2 Your Welder's Condition

- Check cables, power cord and welding cable to be sure the insulation is not damaged. Always replace or repair damaged components before using the welder.
- Check all components to ensure they are clean and in good operating condition before use.

1.3 Use of Your Welder

▲ CAUTION

Do not operate the welder if the output cable, electrode, MIG gun, wire or wire feed system is wet. Do not immerse them in water. These components and the welder must be completely dry before attempting to use it.

- Follow the instructions in this manual.
- Keep welder in the off position when not in use.
- Connect ground lead as close to the area being welded as possible to ensure a good ground.
- Do not allow any body part to come in contact with the welding wire if you are in contact with the material being welded, ground or electrode from another welder.
- Do not weld if you are in an awkward position. Always have a secure stance while welding to prevent accidents. Wear a safety harness if working above ground.
- Do not drape cables over or around your body.
- Wear a full coverage helmet with appropriate shade (see ANSI Z87.1 safety standard) and safety glasses while welding.
- Wear proper gloves and protective clothing to prevent your skin from being exposed to hot metals, UV and IR rays.
- Do not overuse or overheat your welder. Allow proper cooling time between duty cycles.
- Keep hands and fingers away from moving parts and stay away from the drive rolls.
- Do not point MIG gun at any body part of yourself or anyone else.
- Always use this welder in the rated duty cycle to prevent excessive heat and failure.

1.4 Specific Areas of Danger, Caution or Warning

Electrical Shock

▲ WARNING

Electric arc welders can produce a shock that can cause injury or death. Touching electrically live parts



- can cause fatal shocks and severe burns. While welding, all metal components connected to the wire are electrically hot. Poor ground connections are a hazard, so secure the ground lead before welding.
- Wear dry protective apparel: coat, shirt, gloves and insulated footwear.
- Insulate yourself from the work piece. Avoid contacting the work piece or ground.
- Do not attempt to repair or maintain the welder while the power is on.
- Inspect all cables and cords for any exposed wire and replace immediately.
- Use recommended replacement cables and cords.
- Always attach ground clamp to the work piece or work table as close to the weld area as possible.
- Do not touch the welding wire and the ground or grounded work piece at the same time.
- Do not use a welder to thaw frozen pipes.



Fumes and Gases

▲ WARNING

- Fumes emitted from the welding process displace clean air and can result in injury or death.
- Do not breathe in fumes emitted by the welding process. Make sure your breathing air is clean and safe.
- Work only in a well-ventilated area or use a ventilation device to remove welding fumes from the environment where you will be working.
- Do not weld on coated materials (galvanized, cadmium plated or containing zinc, mercury or barium). They will emit harmful fumes that are dangerous to breathe. If necessary use a ventilator, respirator with air supply or remove the coating from the material in the weld area.

- The fumes emitted from some metals when heated are extremely toxic. Refer to the material safety data sheet for the manufacturer's instructions.
- Do not weld near materials that will emit toxic fumes when heated. Vapors from cleaners, sprays and degreasers can be highly toxic when heated.



UV and IR Arc Rays

▲ DANGER

- The welding arc produces ultraviolet (UV) and infrared (IR) rays that can cause injury to your eyes and skin. Do not look at the welding arc without proper eye protection.
- Always use a helmet that covers your full face from the neck to top of head and to the back of each ear.
- Use a lens that meets ANSI standards and safety glasses. For welders under 160 Amps output, use a shade 10 lens; for above 160 Amps, use a shade 12. Refer to the ANSI standard Z87.1 for more information.
- Cover all bare skin areas exposed to the arc with protective clothing and shoes. Flame-retardant cloth or leather shirts, coats, pants or coveralls are available for protection.
- Use screens or other barriers to protect other people from the arc rays emitted from your welding.
- Warn people in your welding area when you are going to strike an arc so they can protect themselves.

Fire Hazards

▲ WARNING



- Do not weld on containers or pipes that contain or have had flammable, gaseous or liquid combustibles in them. Welding creates sparks and heat that can ignite flammable and explosive materials.

- Do not operate any electric arc welder in areas where flammable or explosive materials are present.
- Remove all flammable materials within 35 feet of the welding arc. If removal is not possible, tightly cover them with fireproof covers.
- Take precautions to ensure that flying sparks do not cause fires or explosions in hidden areas, cracks or areas you cannot see.
- Keep a fire extinguisher close in the case of fire.
- Wear garments that are oil-free with no pockets or cuffs that will collect sparks.
- Do not have on your person any items that are combustible, such as lighters or matches.
- Keep work lead connected as close to the weld area as possible to prevent any unknown, unintended paths of electrical current from causing electrical shock and fire hazards..



Hot Materials

⚠ CAUTION

Welded materials are hot and can cause severe burns if handled

improperly.

- Do not touch welded materials with bare hands.
- Do not touch electrode after welding until it has had time to cool down.

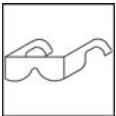

Sparks/Flying Debris

⚠ CAUTION

Welding creates hot sparks that can cause injury. Chipping slag off welds creates flying debris.

- Wear protective apparel at all times: ANSI-approved safety glasses or shield, welder's hat and ear plugs to keep sparks out of ears and hair.



Electromagnetic Field

⚠ CAUTION

- Electromagnetic fields can interfere with various electrical and electronic devices such as pacemakers.
- Consult your doctor before using any electric arc welder or cutting device
- Keep people with pacemakers away from your welding area when welding.
- Do not wrap cable around your body while welding.
- Wrap electrode holder/cable and ground cable together whenever possible.
- Keep electrode holder/cable and ground cables on the same side of your body.



Shielding Gas Cylinders Can Explode

⚠ WARNING

High pressure

cylinders can explode if damaged, so treat them carefully

- Never expose cylinders to high heat, sparks, open flames, mechanical shocks or arcs.
- Do not touch cylinder with MIG gun
- Do not weld on the cylinder.
- Always secure cylinder upright to a cart or stationary object.
- Keep cylinders away from welding or electrical circuits.
- Use the proper regulators, gas hose and fittings for the specific application
- Do not look into the valve when opening it.
- Use protective cylinder cap whenever possible.

1.5 Proper Care, Maintenance And Repair

⚠ DANGER

- Always have power disconnected when working on internal components.

- Do not touch or handle PC board without being properly grounded with a wrist strap. Put PC board in static proof bag to move or ship.
- Do not put hands or fingers near moving parts such as drive rolls or fan

Assembly

1. Tools required for assembly:
Open-end wrenches 8 and 10mm.
2. 1. Lay the machine side panel on a flat surface. Install the metal bracket support on the bottom using two sets of screws and washers from the hardware bag. See following image

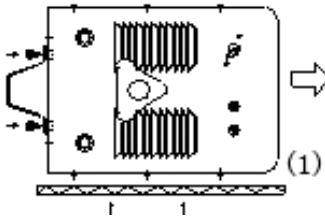

2. Install the axle tube/bracket for the axles and wheels on the axle. See image 2.1 as following. Stand the machine up and install the axle tube/bracket onto the back of panel using the screws and washers provided. (You may want to use a wooded block to hold the welder up for this step.)

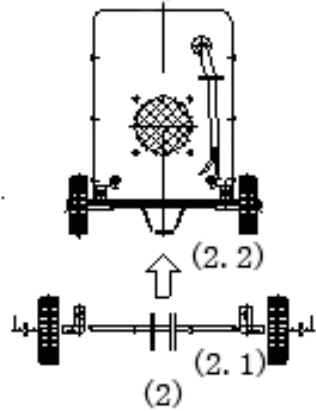

3. Finally, install the handle using four sets of screw and washers as following:

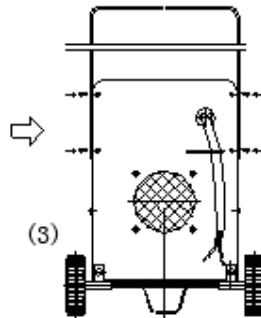

▲ CAUTION

1. Make sure the welder is disconnected to the power supply when assembling
2. When machine is laid on it's side do it gently or the impact could damage internal components.
3. During installation use caution not to do personal injury from lifting.

Installation

1. Power requirement

AC single phase 230v, 60HZ with a 50 amp circuit breaker. DO NOT OPERATE THIS UNIT if the ACTUAL power source voltage is less than 207 volts AC or greater than 253 volts AC.

▲WARNING

- **High voltage danger from power source! Consult a qualified electrician for proper installation of receptacle. This welder must be grounded while in use to protect the operator from electrical shock.**
- **Do not remove grounding prong or alter the plug in any way. Do not use any adapters between the welder's power cord and the power source receptacle. Make sure the POWER switch is OFF when connecting your welder's power cord to a properly grounded 230 VAC, 60Hz, single phase, 50 amp power source.**

2. Extension cord

It is strongly recommended that an extension cord should not be used because of the voltage drop it produces. This drop in voltage can affect the performance of the welder. If you need to use an extension cord it must be a #12 gauge cord or larger. Do not use an extension cord over 25 ft. in length.

3. Setting up the work piece

3.1 Welding positions

There are two basic positions, for welding: Flat and Horizontal. Flat welding is generally easier, faster, and allows for better penetration. If possible, the work piece should be positioned so that the bead will run on a flat surface.

3.2 Preparing the Joint

Before welding, the surface of work piece needs to be free of dirt, rust, scale, oil or paint or it will create

brittle and porous welds. If the base metal pieces to be joined are thick or heavy, it may be necessary to bevel the edges with a metal grinder, the correct bevel should be around 60 degree. See following picture:

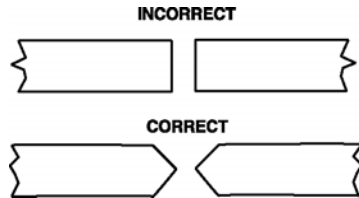

Based on different welding position, there are different welding joint, see following images for more information

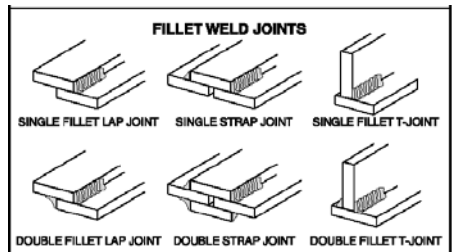
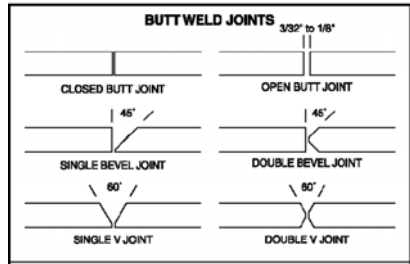

4. Ground clamp connection

Clear any dirt, rust, scale, oil or paint on the ground clamp. Make certain you have a good solid ground connection. A poor connection at the ground clamp will waste power and heat. Make sure the ground clamp touches the metal.

5. Electrode

The welding electrode is a rod coated with a layer of flux. When welding, electrical current flows between the electrode (rod) and the grounded metal work piece. The intense heat of the arc between the rod and the grounded metal melts the electrode and the flux. The most popular electrodes are:

-E6011 60,000 PSI tensile strength deep penetrating applications.

-E6013 60,000 PSI tensile strength used for poor fit up applications

-E7014 70,000 PSI tensile strength used for high deposition and fast travel speeds with light penetration

-E7018AC 70,000 PSI tensile strength, Used for out of position and tacking.

6. Selecting the proper electrode

There is no golden rule that determine the exact rod or heat setting required for every situation. The type and thickness of metal and the position of the work piece determine the electrode type and the amount of heat needed in the welding process. Heavier and thicker metals required more amperage. It is best to practice your welds on scrap metal which matches the metal you intend to work with to determine correct heat setting and electrode choice. See the following helpful trouble shooting tips to determine if you are using a correct electrode

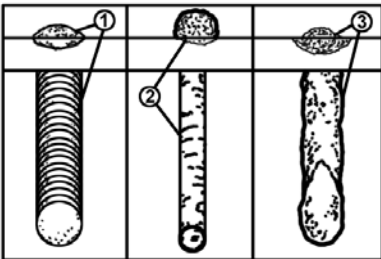

1. When proper rod is used:

- a. The bead will lay smoothly over the work without ragged edges
 - b. The base metal puddle will be as deep as the bead that rises above it
 - c. The welding operation will make a crackling sound similar to the sound of eggs frying
2. When a rod too small is used;
 - a. The bead will be high and irregular
 - b. The arc will be difficult to maintain
 3. When the rod is too large
 - a. The arc will burn through light metals
 - b. The bead will undercut the work
 - c. The bead will be flat and porous
 - d. Rod may be freeze or stick to work piece

Note: Rate of travel over the work also affects the weld. To ensure proper penetration and enough deposit of rod, the arc must be moved slowly and evenly along the weld seam.

Operation

1. Setting the amperage control

The welder has an infinite current control. It is capable of welding with electrodes up to 5/32" diameter. There is no golden rule that determines the exact amperage required for every situation. It is best to practice your welds on scrap metal which matches the metals you intend to work with to determine correct setting for your job. The electrode type and the thickness of the work piece metal determine the amount of heat needed in the welding process. Heavier and thicker metals require more voltage (amperage), whereas lighter and thinner metals require less voltage (amperage).

2. Welding techniques

The best way to teach yourself how to weld is with short periods of practice at regular intervals. All practice welds should be done on scrap metal that can be discarded. Do not attempt to make any repairs on valuable equipment until you have satisfied yourself that your practice welds are of good appearance and free of slag or gas inclusions.

2.1 Holding the electrode

The best way to grip the electrode holder is the way that feels most comfortable to you. Position the Electrode to the work piece when striking the initial arc it may be necessary to hold the electrode perpendicular to the work piece. Once the arc is started the angle of the electrode in relation to the work piece should be between 10 and 30 degrees. This will allow for good penetration, with minimal spatter.

2.2 Striking the arc

▲ WARNING

EXPOSURE TO A WELDING ARC IS EXTREMELY HARMFUL TO THE EYES AND SKIN.

- *Never strike an arc or begin welding until you have adequate protection.*
- *Wear flameproof welding gloves, heavy long-sleeved shirt, cuffless trousers, high-topped shoes and a welding helmet or shield.*

Scratch the work piece with the end of electrode to start arc and then raise it quickly about 1/8 inch gap between the rod and the work piece, see following picture

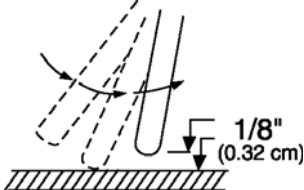

It is important that the gap be maintained during the welding process and it should be neither too wide or too narrow. If too narrow, the rod will stick to the work piece. If too wide, the arc will be extinguished. It needs much practice to maintain the gap. The beginners may usually get sticker or arc extinguishing. When the rod is stick to the work piece, gently rock it back and forth to make them separate. If not, the circuit is short connection, it will break the welder.

A good arc is accompanied by a crisp, cracking sound. The sound is similar to that made by eggs frying. To lay a weld bead, only 2 movements are required; downward and in the direction the weld is to be laid, as in following figure:

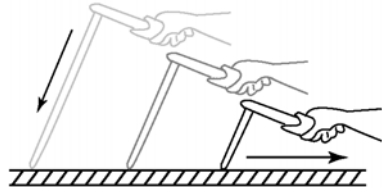

2.3 Types of weld bead

The following paragraphs discuss the most commonly used arc welding beads.

The stringer bead Formed by traveling with the torch in a straight line while keeping the wire and nozzle centered over the weld joint.

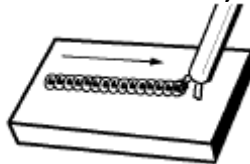

The weave bead Used when you want to deposit metal over a wider space than would be possible with a stringer bead. It is made by weaving

from side to side while moving with the torch. It is best to hesitate momentarily at each side before weaving back the other way penetration.

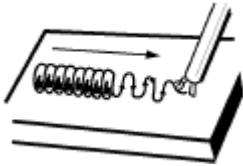

2.4 Welding position

Flat position It is easiest of the welding positions and is most commonly used. It is best if you can weld in the flat position if at all possible as good results are easier to achieve.

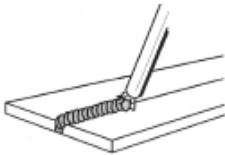

The horizontal position it is performed very much the same as the flat weld except that the angle is different such that the electrode, and therefore the arc force, is directed more toward the metal above the weld joint. This more direct angle helps prevent the weld puddle from running downward while still allowing slow enough travel speed to achieve good penetration. A good starting point for your electrode angle is about 30 degrees DOWN from being perpendicular to the work piece.



2.5 Judge the good weld bead

When the trick of establishing and holding an arc has been learned, the next step is learning how to run a

good bead. The first attempts in practice will probably fall short of acceptable weld beads. Too long of an arc will be held or the travel speed will vary from slow to fast (see following)

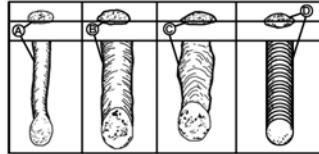

- A. Weld speed is too fast.
- B. Weld speed is too slow.
- C. Arc is too long.
- D. Ideal weld.

A solid weld bead requires that the electrode be moved slowly and steadily along the weld seam. Moving the electrode rapidly or erratically will prevent proper fusion or create a lumpy, uneven bead. To prevent ELECTRIC SHOCK, do not perform any welding while standing, kneeling, or lying directly on the grounded work.

2.6 Finish the bead

As the coating on the outside of the electrode burns off, it forms an envelope of protective gasses around the weld. This prevents air from reaching the molten metal and creating an undesirable chemical reaction. The burning coating, however, forms slag. The slag formation appears as an accumulation of dirty metal scale on the finished weld. Slag should be removed by using a chipping hammer.

▲WARNING

PEENING THE SLAG FROM A WELD JOINT CAUSES SMALL CHIPS OF METAL TO FLY THROUGH THE AIR

• Metallic chips flying through the air can cause eye injury or injury to other parts of the head, hands or exposed portions of the body.

• *Wear goggles or eye glasses with side shields and protect the hands and other exposed parts of the body with protective garments, or if possible, work with a shield between the body and the work piece.*

The intense heat produced at the arc sets up strains in the metal joined by welding. Peening the weld not only removes the scale left behind in the welding but relieves the internal strains developed by the heating and cooling process.

Maintenance

The welder needs regular maintenance.

Periodically clean dust, dirt, grease, etc. from your welder. Every six

months, or as necessary, remove the cover panel from the welder and air-blow any dust and dirt that may have accumulated inside the welder.

Replace power cord, ground cable, ground clamp, or electrode assembly when damaged or worn.

MINOR AND ROUTINE MAINTENANCE

Store in a clean dry location free from corrosive gas, dust and high humidity. A temperature range from 10° F - 120°F and the relative humidity less than 90%.

When transporting or storing the welder after use, it is recommended to repack the product as it was received for protection. (Cleaning is required before storage and you must seal the plastic bag in the box for storage)

Circuit Chart

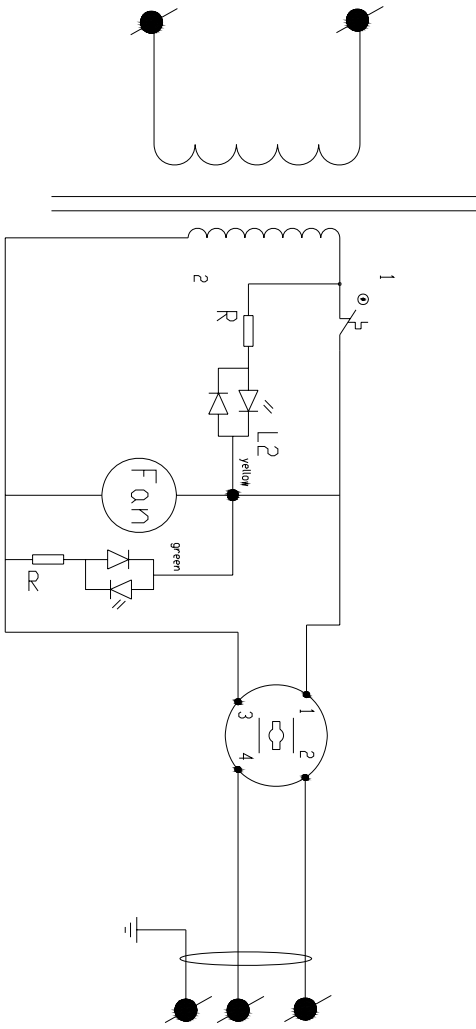

Trouble shooting Chart

Symptom (s)	Possible Causes(s)	Corrective Action(s)
Welder does not work when the turn on the main switch	1.No power input 2.The power cord or power plug is broken 3.Main switch is broken 4.Transformer is broken	1.Check circuit breaker or fuse in power source 2.Replace power cord 3.Replace switch 4.Replace the transformer
Does not weld	1.Incorrect power input 2.Inadequate current at output 3.Poor connection of output cable 4. Dirty surfaces 5. Wrong welding wire	1.Check the power source 2.Check for proper grounding to the work piece. 3.Check output connection 4. Clean surfaces 5. Use correct wire
Blows fuse	Wrong fuse in power supply	Check the fuse in power source should be 50amp
Arc is hard to start	1. The wrong electrode 2. Base metal not grounded properly	1. Use recommended electrode 2.Make sure there is a good ground connection
Welding bead too thin	The welding speed is too fast	Slow down the welding speed
Welding bead too thick	The welding speed is too slow	Speed up the welding speed
Electrode sticks to work piece	Electrode is kept to contact work piece too long time when starting arc	After arc starting, move the electrode away from the work piece immediately
Poor welding performance, spatter	1.Damp electrode 2.Wrong type electrode	1. Use dry one 2. Use correct one
Other		Call Tech Help

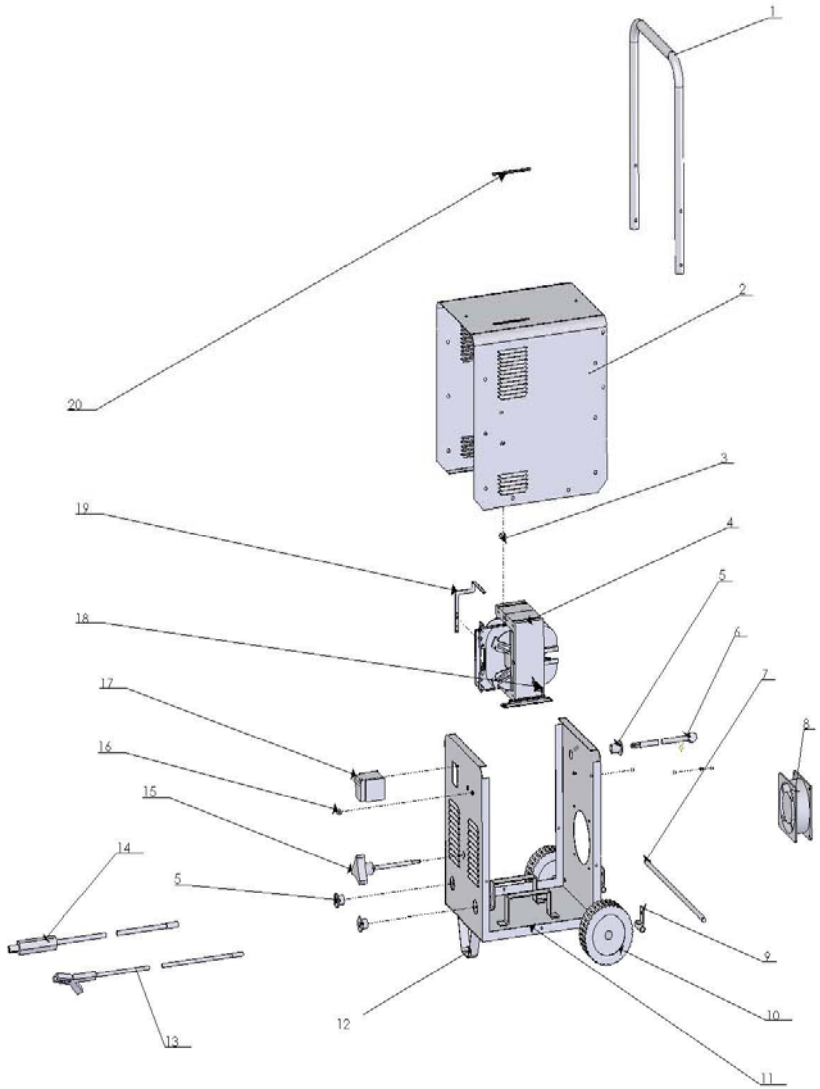

AC4180D

Repair Parts List

Reference number	Description	Part number	Qty
1	Handle	1.06.201.03	1
2	Panel	1.06.201.01	1
3	Spring	2.06.29.051	2
4	Transformer	1.06.201.31	1
5	Cable holder	2.05.05.201	1
6	Power cord	2.03.05.148	1
7	Spindle	1.06.201.12	1
8	Fan	2.07.89.012	1
9	Axle bracket	5.02.01.059	2
10	Wheel	1.06.300.40	2
11	Frame plate	1.06.201.35	1
12	Brake	1.06.300.05	1
13	Ground cable clamp	1.01.1160.11	1
14	Welding cable electrode holder	1.01.1160.10	1
15	Hand wheel	2.05.08.002	1
16	Indicator light	2.07.28.209	1
17	Power Switch	2.07.80.421	1
18	Spring	2.06.29.221	1
19	Pointer	1.06.201.02	1
20	Index panel*	2.05.18.007	1

Other Safety and Standards Information

This manual is designed to inform the operator of safety and general use of this model only. For further information about welding safety refer to the following standards and comply with them where applicable.

- **ANSI Standard Z49.1** — SAFETY IN

WELDING AND CUTTING obtainable
from: American Welding Society 550 NW

Le Jeune Road, Miami, FL 33126

Tel. (800) 443-9353 Fax (305) 443-7559

www.amweld.org or www.aws.org

- **ANSI Standard Z87.1** — SAFE PRACTICE
FOR OCCUPATION AND EDUCATIONAL
EYE AND FACE PROTECTION

Obtainable from: American National
Standards Institute (ANSI) 11 West 42nd

St. New York, NY 10036

Tel. (212) 642-4900 Fax (212) 398-0023 www.ansi.org

- **NFPA Standard 51B** — CUTTING AND

WELDING PROCESS obtainable from:

National Fire Protection Association,

1 Batterymarch Park, P.O. Box 9101

Quincy, MA 02269-9101

Tel. (617) 770-3000 Fax (617) 770-0700 www.nfpa.org

- **OSHA Standard 29 CFR**, Part 1910,
Subpart Q. —WELDING, CUTTING AND
BRAZING obtainable from your state

OSHA office or from: U. S. Dept. of Labor

OSHA, Office of Public Affairs Room

N3647, 200 Constitution Ave. NW

Washington, DC 20210 www.osha.gov

- **CSA Standard W117.2** — Code for
SAFETY IN WELDING AND CUTTING

Obtainable from: Canadian Standards

Association, 178 Rexdale Blvd.,

Etobicoke, Ontario M9W 1R3

www.csa.ca

- **American Welding Society Standard A6.0**

—WELDING AND CUTTING CONTAINERS
WHICH HAVE HELD COMBUSTIBLES

Obtainable from: American

Welding Society, 550 NW Le Jeune Road

Miami, FL 33126

Tel. (800) 443-9353 Fax (305) 443-7559

www.amweld.org or www.aws.org

Warranty

Northern Tool + Equipment

Effective Jan 1, 2010

Limited Warranty

This warranty applies to the original purchaser and is subject to the terms and conditions listed below. This Limited Warranty is for new equipment sold after the above date, providing coverage for defects in material and workmanship at the time it is shipped from the factory.

Limited to the warranty periods listed below, Northern Tool + Equipment will repair or replace the item under warranty that fails due to defects in material and workmanship. Northern Tool + Equipment must be notified within 30 days of the failure, so as to provide instructions on how to proceed with the repair of your welder and warranty claim processing. Warranty period begins at the time the welder is purchased from Northern Tool + Equipment.

Warranty Periods

Limited Warranty is divided into four categories: No warranty, 6 months, 1 year, 3 year.

No Warranty

Normal wear items, MIG gun parts (contact tips, nozzle, adapter, MIG gun liner), drive roll, contactor, plasma torch parts (electrode, shield), TIG torch parts (tungsten, collet, back caps), electrode holder, are not covered under warranty.

6 Months

Parts and labor performed by authorized repair center with original equipment repair parts

1 Year

Contactor, MIG gun parts (except those listed under normal wear items), Plasma torch (except those listed under normal wear items), TIG torch (except those listed under normal wear items), cables, remote amperage controls, regulator.

2 Year

Includes: transformer, reactor, rectifier, solenoid valve, PC board, switches, controls, gas valve, drive motor, drive system.

Northern Tool + Equipment Co.
2800 Southcross Drive West
PO Box 1219
Burnsville MN 55337